

5-5/8" Diameter (High Efficiency) Indoor Blower Motors

Fan Coils - Dual Wheel Blower

Features:

- Auto Protector
- Continuous Air Over
- High Efficient \$
- Open Construction
- Multiple Mount
- Resilient Mounting Rings Included
- Reversible
- Permanent Split Capacitor
- 1/2" Dia. - Flatted Shaft
- 23" Leads (Minimum)
- 40°, 50° and 60°C Ambient
- 48 Frame (5-5/8" Dia.)
- 60 HZ

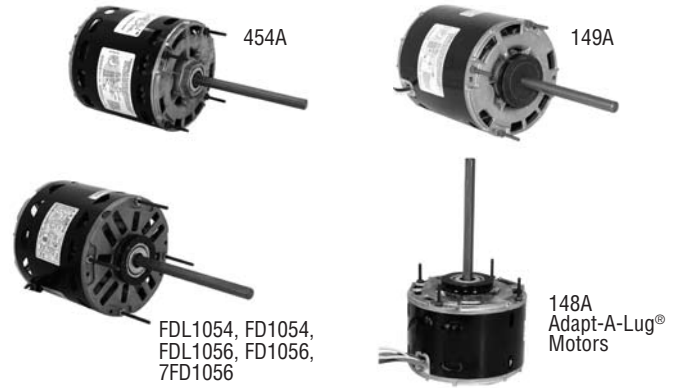

OEM replacement for Bard, Chrysler, York, Armstrong, Johnson, Janitrol, Bohn, Lennox, Copeland, Fedders, Heil Quaker, American Standard, Bryant, Westinghouse, Carrier, Peerless and others.

THREE SPEED – ELECTRICALLY REVERSIBLE (CAPACITOR NOT INCLUDED)

HP	RPM**	Speeds	Volts	Amps	Stock Number	Capacitor	Bearings	Dim. Ref.	Notes
1/2	1075	3	115	5.6	FDL1056	10MFD-370V	Sleeve	2	9,90,\$
1/2	1075	3	208-230	2.7	FD1056	7.5MFD-370V	Sleeve	2	9,90,\$
1/2	1075	3	208-230	3.0	149A	7.5MFD-370V	Ball	1	9,29,\$
1/2	1075	3	277	2.2	7FD1056	10MFD-370V	Sleeve	3	9,90,\$
1/2	1625	3	115	7.6	FDL1054	15MFD-370V	Sleeve	2	9,31,\$
1/2	1625	3	208-230	2.8	FD1054	7.5MFD-370V	Sleeve	2	9,31,\$

Notes:

- 9. Reversing plug
- 10. Reversible/Quick Connect terminals
- 29. 60° C Ambient
- 31. 40° C Ambient
- 46. Adapt-A-Lug Motors (See Page 263 for Lugs)
- 75. Mounting rings not included
- 90. 50° C Ambient
- **Approx 150 rpm between speeds

Continues on next page

Approximate Dimensions

Ref.	BM	R	C	N	T
1	5.00	5.47	9.98	4.98	0.61
2	5.11	5.67	11.55	6.44	1.62
3	5.36	5.92	11.80	6.44	1.62

